



# User's Guide and Operator Instructions

CBS-5000H Series Coffee Brewers Models: CBS-51H15; CBS-52H15; CBS-52H20  
FETCO Commercial Beverage Equipment



Left: Single 1 1/2 Gal CBS-51H15

Center: Dual 1 1/2 Gal CBS-52H15

Right: Dual 2 Gal CBS-52H20

Contact Information  
FETCO®  
Food Equipment Technologies Company  
600 Rose Road  
Lake Zurich • IL • 60047-1560 • USA  
© 2008-2019 Food Equipment Technologies Company



Internet: [www.fetco.com](http://www.fetco.com)  
Phone: (800) 338-2699 (US & Canada)  
(847) 719-3000  
Fax: (847) 719-3001  
Email: [sales@fetco.com](mailto:sales@fetco.com)  
[techsupport@fetco.com](mailto:techsupport@fetco.com)



## Table of Contents

Introduction.....	2	Installation.....	5
Product Description/Features.....	2	Operating Procedures.....	7
Specifications .....	2	Service .....	8
Dimensions & Utility Connections .....	4	Brewer Parts .....	13
		Troubleshooting .....	20

## Introduction

This manual applies only to CBS-5000H 1½ gallon and 2 gallon series brewers manufactured after 2006. The 1gallon CBS-51H10 was discontinued in 2010. The steam powered option was discontinued in 2011. Refer to User's Guide # P102 CBS-51H10 one gallon versions and for steam powered versions. Refer to User's Guide # P004 for mercury relay versions.

## Product Description/Features

### CBS-51H15 - Single 1.5 Gallon Coffee Brewer

### CBS-52H15 - Twin 1.5 Gallon Coffee Brewer

### CBS-52H20 - Twin 2.0 Gallon Coffee Brewer

- Thermal, portable, beverage dispensers
- Stainless steel, gourmet size brew baskets
- Brew basket double safety locks
- Open type, leak free dispense system
- Fully automatic, with electronic temperature control
- Two level tank drain system
- Total serviceability from the front

- Optional Features:
- Export voltage
- 3.0 liter airpots, with stands,
- Half batch brewing capability\*
- Iced tea brewing capability\*

\* Can be added at any time.

## Specifications

<b>Brew Volume:</b>	<b>CBS-51H15 &amp; CBS-52H15</b>	<b>CBS-52H20</b>
Full Batch	1 ½ gal. (5.7 lit.)	2 gal. (7.6 lit.)
Half Batch ½ gal.	¾ gal. (2.8 lit.)	1 gal. (3.8 lit.)

<b>Brew Time:</b>	<b>CBS-51H15 &amp; 52H15</b>	<b>CBS-52H20</b>
Full Batch.	4 - 4 ½ min.	5 ½ - 6 min.
Half Batch	2 - 2 ¼ min.	2 ¾ - 3 min.

*(Allow an extra 2-4 minutes for coffee to finish dripping)*

<b>Coffee Filter Size:</b>	<b>CBS-51H15, CBS-52H15, &amp; CBS-52H20</b>
	15" X 5 ½" – standard
	13" X 5" – optional half batch

<b>Temperature:</b>
205°F inside water tank (at sea level)
195°F ± 5° at sprayhead

**Bypass Range:** 0 to 33%  
*(factory set at 0% unless specified)*

<b>Water Requirements:</b> 20-75 psig
CBS-51H ½ gpm
CBS-52H 1 ¼ gpm

## Weights and Capacities

Brewer Model	Weight (empty)	Water tank Capacity & Weight.		Weight (filled)	Dispenser Weight, ea.	Dispenser Filled, ea..	Total Weight Brewer & Dispensers, Filled
CBS-51H15	55 lbs.	3.7 gal.	31 lbs.	86 lbs.	8.5 lbs.	21 lbs.	107 lbs.
CBS-52H15	82 lbs.	7.6 gal.	63 lbs.	145 lbs.	8.5 lbs.	21 lbs.	187 lbs.
CBS-52H20	87 lbs.	7.6 gal.	63 lbs.	150 lbs.	10 lbs.	26.6 lbs.	203.2 lbs.

## Electrical Configuration and Brewing Efficiency

### CBS-51H15

1.5 gallons per batch

Electrical Config. Code	Heater Configuration	Voltage Connection	Phase	Wires	KW	Maximum Amp draw	Batches per Hour (max 11)	
							Cold Water	Hot Water
C51016	1 X 1800 watt	120	1 ph.	2 + ground	1.9	15.5	3.0	6.8
		120/208	1 ph.	3 + ground	2.3	11.3	3.7	8.6
C51026	1 X 3000 watt	120/220	1 ph.	3 + ground	2.6	12.0	4.3	10.0
		120/240	1 ph.	3 + ground	3.1	13.0	5.0	11.0
C51036	1 X 4000 watt	120/208	1 ph.	3 + ground	3.1	14.9	5.0	11.0
		120/220	1 ph.	3 + ground	3.4	15.8	5.8	11.0
C51046	2 X 3000 watt	120/240	1 ph.	3 + ground	4.1	17.2	6.6	11.0
		120/208	1 ph.	3 + ground	4.6	22.1	7.4	11.0
		120/220	1 ph.	3 + ground	5.2	23.4	8.6	11.0
C51056	2 X 4000 watt	120/240	1 ph.	3 + ground	6.1	25.5	9.9	11.0
		120/208*	1 ph.	3 + ground	6.1	29.3	9.9	11.0

### CBS-52H15

1.5 gallons per batch

Electrical Config. Code	Heater Configuration	Voltage Connection	Phase	Wires	KW	Maximum Amp draw	Batches per Hour (max 22)	
							Cold Water	Hot Water
C52016	2 X 3000 watt	120/208	1 ph.	3 + ground	4.6	22.4	7.4	17.2
		120/220	1 ph.	3 + ground	5.2	23.7	8.6	19.9
		120/240	1 ph.	3 + ground	6.1	25.8	9.9	22.0
C52026	2 X 4000 watt	120/208	1 ph.	3 + ground	6.1	29.6	9.9	22.0
		120/220	1 ph.	3 + ground	6.8	31.3	11.5	22.0
C52036	3 X 3000 watt	120/240	1 ph.	3 + ground	8.1	34.1	13.2	22.0
		120/208	3 ph.	4 + ground	6.9	19.5	11.2	22.0
		120/220	3 ph.	4 + ground	7.7	20.6	12.9	22.0
C52046	3 X 4000 watt	120/240	3 ph.	4 + ground	9.1	22.4	14.9	22.0
		120/208	3 ph.	4 + ground	9.1	25.8	14.9	22.0
		120/220	3 ph.	4 + ground	10.3	27.3	17.3	22.0
C52186	3 X 4000 watt	120/240	3 ph.	4 + ground	12.1	29.7	19.8	22.0
		480	3 ph.	3 + ground	12.1	15.2	19.8	22.0

### CBS-52H20

2.0 gallons per batch

Electrical Config. Code	Heater Configuration	Voltage Connection	Phase	Wires	KW	Maximum Amp draw	Batches per Hour (max 18)	
							Cold Water	Hot Water
C53016	2 X 3000 watt	120/208	1 ph.	3 + ground	4.6	22.4	5.6	12.9
		120/220	1 ph.	3 + ground	5.2	23.7	6.5	14.9
		120/240	1 ph.	3 + ground	6.1	25.8	7.4	17.2
C53026	2 X 4000 watt	120/208	1 ph.	3 + ground	6.1	29.6	7.4	17.2
		120/220	1 ph.	3 + ground	6.8	31.3	8.6	18.0
C53036	3 X 3000 watt	120/240	1 ph.	3 + ground	8.1	34.1	9.9	18.0
		120/208	3 ph.	4 + ground	6.9	19.5	8.4	18.0
		120/220	3 ph.	4 + ground	7.7	20.6	9.7	18.0
C53046	3 X 4000 watt	120/240	3 ph.	4 + ground	9.1	22.4	11.2	18.0
		120/208	3 ph.	4 + ground	9.1	25.8	11.2	18.0
		120/220	3 ph.	4 + ground	10.3	27.3	12.9	18.0
C53186	3 X 4000 watt	120/240	3 ph.	4 + ground	12.1	29.7	14.9	18.0
		480	3 ph.	3 + ground	12.1	15.2	19.8	22.0

**Dimensions & Utility Connections**  
**CBS-51H15**

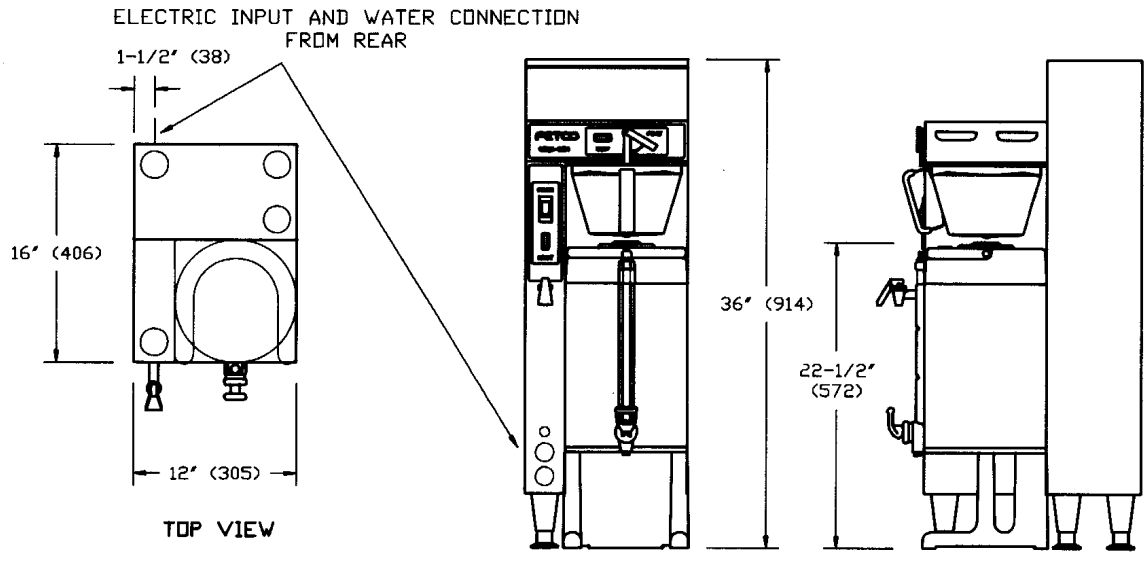

**CBS-52H15**

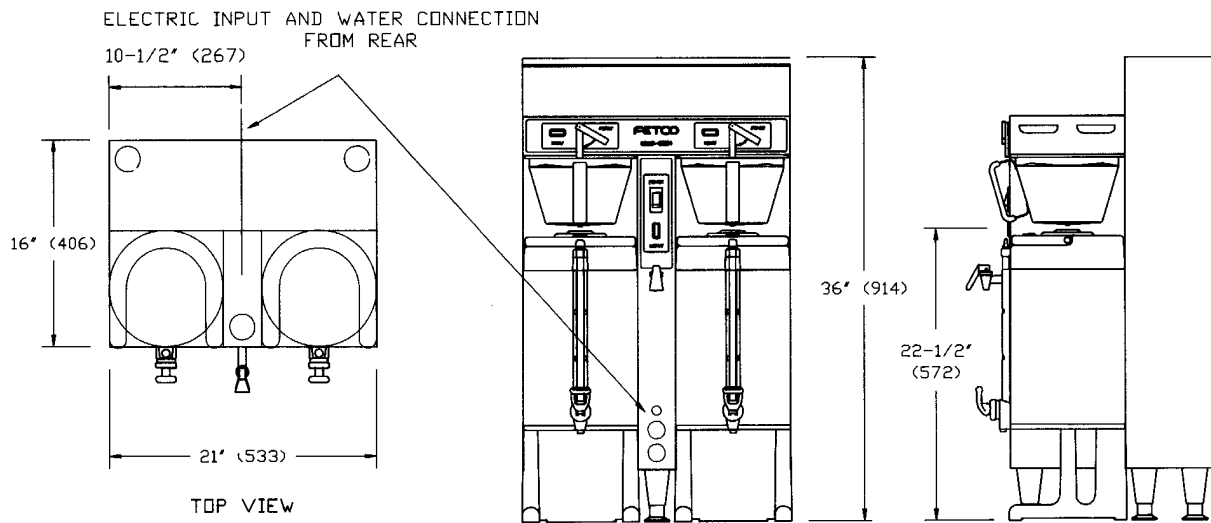

**CBS-52H20**

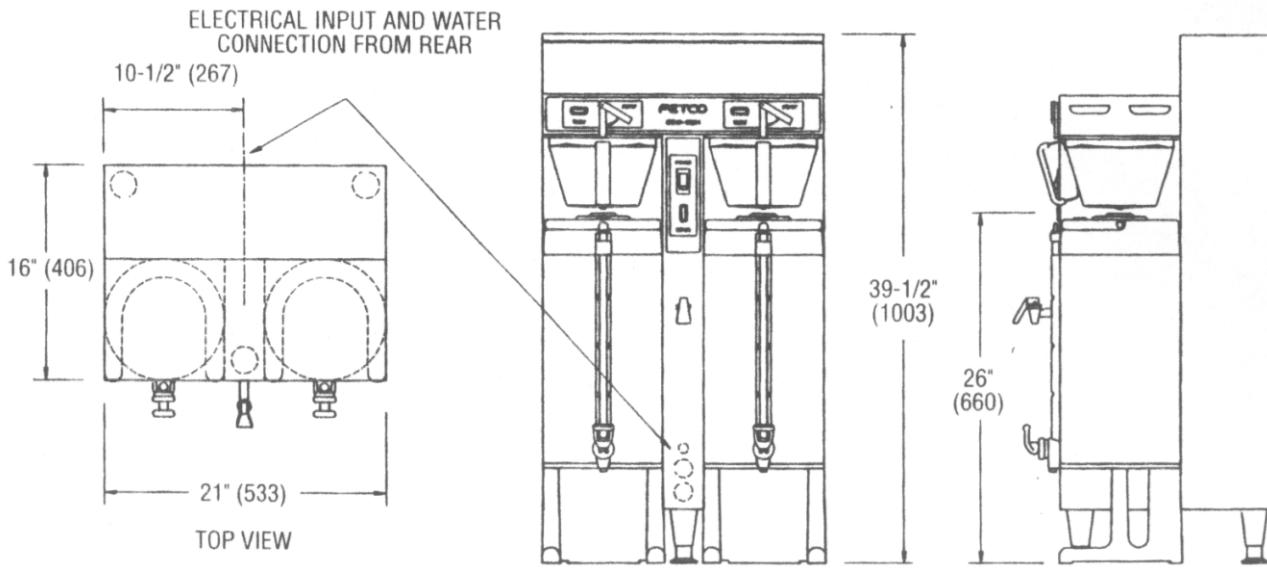

## Installation

(For Qualified Service Technicians Only)

### Keys To A Successful Installation

If not installed correctly by qualified personnel, the brewer may not operate properly, and damage may result. Damages resulting from improper installation are not covered by the warranty. All FETCO Hot Beverage Equipment is designed and sold for commercial use only. Here are the key points to consider before installation:

#### Electrical:

- All FETCO brewers require **NEUTRAL**. Ground is not an acceptable substitute. Installation without neutral may cause damage to the electronic components.
- The power connection to L2 on the terminal block must be at least 105 volts. Less than 105 volts will cause erratic behavior from the brewer.
- The power switch has a built-in circuit breaker. To reset it, turn to the power switch to the “off” position, and then back to the “on” position.
- The electrical drawing for the brewer is located on the inside of the lower cover of the brewer.

#### Plumbing:

- This equipment is to be installed to comply with the applicable federal, state, or local plumbing codes.
- The water line must be flushed thoroughly prior to connecting it to the brewer to prevent debris from contaminating the machine.
- Verify that the water line will provide at least ½ gallons per minute for the CBS-51H, and 1¼ gallons per minute for the CBS-52H before connecting it to the brewer.

#### General:

- Utilize only qualified beverage equipment service technicians for installation. A Service Company Directory may be found on our web site, <http://www.fetco.com>.

## Installation Instructions

### Brewer Setup

1. Review the Dimensions for the unit you are installing. Verify that the brewer will fit in the space intended for it, and that the counter or table will support the total weight of the brewer and dispensers when filled.
2. The brewer’s legs are shipped inside the brew baskets. Remove the brew basket(s) and the coffee dispenser(s). Place the brewer on its back and screw in the legs.
3. Place the brewer on the counter or stand.
4. When the brewer is in position, level it front to back and side to side by adjusting the legs.
5. Remove the lower cover to access the water and electrical connections. Knock-outs are provided in the back and base of the brewer body for the connections.



**Warning: Legs are to be adjusted for leveling the brewer only. Do not use for height adjustment or extend them higher than necessary.**

### Water Connection

1. Water inlet is a 3/8 inch male flare fitting.
2. The brewer can be connected to a cold or hot water line. Cold water is preferred for best coffee flavor, but hot water will allow for faster recovery times.
3. Install a water shut off valve near the brewer to facilitate service. If an in-line water filter is used, it should be installed after the water shut off valve and in a position to facilitate filter replacement.
4. Flush the water supply line and filter **before** connecting it to the brewer.
5. Verify that the water line will provide at least ½ gallons per minute for the CBS-51H, and 1¼ gallons per minute for the CBS-52H, and that the water pressure is between 20 and 75 psig.
6. Use a wrench on the factory fitting when connecting the incoming water line. This will reduce stress on the internal connections and reduce the possibility of leaks developing after the install has been completed.
7. Commercial beverage equipment requires filtered water and an user installed backflow prevention valve. Most municipalities require a recognized backflow preventer. The WATTS® SD-2 or SD-3 is usable on all hot beverage and cold beverage equipment. The WATTS spring loaded double check valve models are accepted by most Authorities Having Jurisdiction (AHJ)

## Electrical Connection

1. Verify that the actual voltage at the electrical service connection is compatible with the specifications on the brewer's serial number label. Make sure the electrical service includes **neutral**.
2. The temperature and water tank fill level are pre-set at the factory. There is no need to turn off the heaters during the installation process. The control board disables the heaters until the tank is full of water. The heating process will start automatically when the tank has filled.
3. Only 120VAC powered units are shipped from the factory with power cords and plugs attached. For other voltages, a terminal block is provided for connecting the incoming power wires. Consult local codes to determine if a cord and plug can be installed, or if the unit must be hard wired.
4. A fused disconnect switch or circuit breaker on the incoming power line must be conveniently located near the brewer, and its location and markings known to the operators.
5. The body of the brewer must be grounded to a suitable building ground. A ground lug is provided in the brewer next to the power terminal block. Use only 10 gauge copper wire for grounding.
6. Electrical connections must be secured in-place within the unit to meet national and local standards.

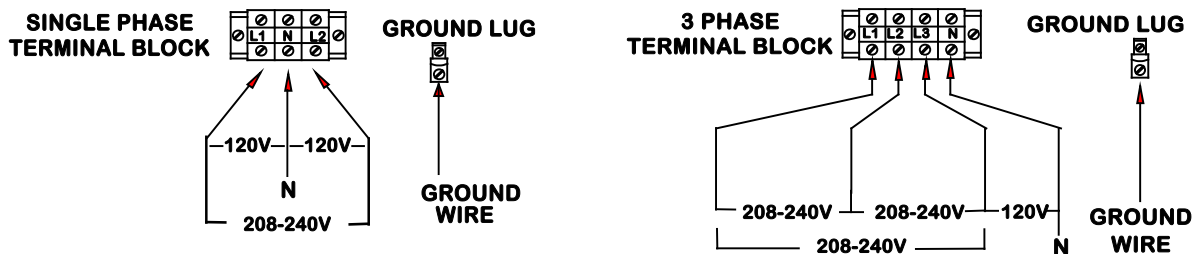
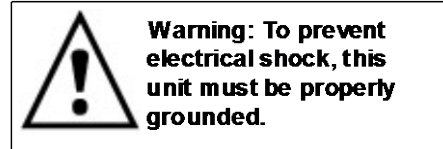

**Electrical Configurations – US & Canada**

7. Finally, connect the incoming power wires to the terminal block in accordance with applicable codes.

## Final Setup

1. Turn on the incoming water supply line and inspect both inside and outside of the brewer for leaks in all fittings and tubes
2. Turn on the incoming power.
3. Turn on the brewer's main power switch.
4. Within 6 seconds, the hot water tank will begin filling until the probe at the top of the tank senses the water.
5. The control board will disable the heaters until the tank is full.
6. The brewer will be ready for operation as soon as the ready light comes on to signify that the water tank is up to temperature. The time required to reach brewing temperature will vary according to the electrical configuration ordered.
7. Review the Operating Instructions. Brew one full batch (water only) on each side to confirm proper fill levels. The brewer is factory set with water only (no coffee) to dispense the correct amount of water.
8. Re-attach the covers after one final inspection for leaks. Look closely in the top of the brewer at the dispense fittings during this inspection.

## Operator Training

Review the operating procedures with whoever will be using the brewer. Pay particular attention to the following areas:

1. Always pre-heat the dispensers before the first use of each day by filling them half way with hot water, and letting them stand for at least 15 minutes.
2. Don't remove the brew basket until it has stopped dripping.
3. Make sure the dispenser is empty before brewing into it.
4. Show how to attach covers, close, and or secure the thermal dispensers for transporting.
5. Show the location and operation of the water shut off valve as well as the circuit breaker for the brewer.
6. Steam from the tank will form condensation in the vent tubes. This condensation will drip into and then out of the brew baskets. 1/4 cup discharging overnight is possible. Place an appropriate container under each brew basket when not in use.
7. We recommend leaving the power to the brewer on overnight. The water tank is well insulated and will use very little electricity to keep the tank hot. Leaving the brewer in the on position will also avoid delays at the beginning of shifts for the brewer to reach operating temperature.

## Operating Procedures

### 1. Turn brewer on/off switch (E) to the on position

- The power switch will illuminate to indicate that the brewer has power and is operating.
- When the **ready light** (F) illuminates, the brewer is fully up to temperature. The amount of time required to gain full operating temperature will vary depending on the electrical configuration that was ordered, and the temperature of the incoming water.

### 2. Pre-heat the dispensers.

This step is very important to the overall success of the brewing operation. FETCO avoids the damaging affects of heat on fresh brewed coffee by using highly insulated dispensers. The dispenser must be pre-heated with hot water from the brewer. This preheating process ensures that the coffee in the first brew starts out hot. Significant heat loss will occur when brewing coffee into a cold dispenser. Preheating is not required for subsequent brews unless the dispenser remains empty for an extended period of time and has cooled down.

- Slide the empty brew basket(s) (D) into their rails and put the empty dispenser(s) in position under the basket for preheating. Select the half batch mode, (A) if you have this option.
- When the ready light illuminates, start a brew cycle by rotating the brew lever (B) to the brew position. This starts clean hot water flowing into the brew basket and then into the dispenser.
- Stop the cycle when each dispenser is approximately 1/2 full by moving the brew lever to the off position. This interrupts the brew cycle and resets the brewer.
- Let the dispensers stand 10-15 minutes, or until use, to allow the heat from the water to be absorbed by the dispensers.

### 3. Remove the brew baskets from the brewer when you are certain that the flow of hot water has stopped from the bottom of the basket.

- H model brewers will have a safety bar (C) in front of the brew basket to make removing the brew basket a 2-handed operation. This was done to help draw attention to the basket so the operator will notice any residual hot water or coffee.
- Place a paper filter in each basket to be used. Pour into the paper filter the appropriate amount of pre-measured, ground coffee. The amount of coffee used will depend on your personal tastes and the recommendation of your roaster.
- Slide the brew basket back into the rails on the brewer. Insure the latch is outside of the basket.

### 4. Carefully drain any coffee or preheating water from the dispensers through the faucets before starting a coffee brewing cycle.

- Overflowing of the dispensers may result if the dispensers are not completely empty when the brew cycle begins. Verify by opening the faucet over an appropriate container or drain. The last several cups cannot be seen in the sight gauge tube.
- **CAUTION:** both the coffee or water may still be hot enough to cause burns, so be careful when draining the dispensers

### 5. Place the thermal dispenser(s) in position under the brew baskets.

- Ensure that the brew funnel is in place, the dispenser is empty, and the faucet is closed. If you are using TPD-1.5 dispensers, also make sure the vent cap on the sight gauge is open.
- The twist lock cover (TPD-1.5 dispensers) is for transporting the dispenser only. It must be removed before placing the dispenser under the brew basket.

### 6. Start the brew cycle in the same manner used to start the water used to preheat the dispensers.

- It will not be necessary to interrupt the cycle while brewing coffee. The brewer will return to the stopped and ready status automatically.
- It is normal for the ready light to go out after the start of the brew cycle. On twin brewers, there is enough hot water in the brewer to support a second brew, even if the ready light is off. After brewing on both sides, you must wait for the ready light to come back on.
- The electrical configuration and the electrical power connected to the brewer will determine how long before the ready light comes back on for the next brew.

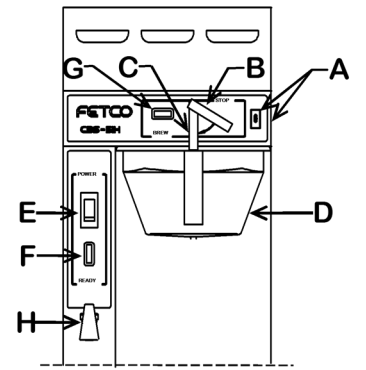

#### Legend:

- A**-Full/half batch switch
- B**-Brew lever
- C**-Safety bar
- D**-Brew basket
- E**-On/off switch
- F**-Ready light
- G**-Brew light
- H**-Hot water faucet

(Continued on next page)

## CAUTION

- **Do not remove the brew basket immediately after the brew cycle has finished. Wait until dripping from the bottom of the brew basket has stopped. Carefully remove the brew basket while inspecting the inside of the basket for hot coffee that may have been trapped or has not finished draining.**

---

## Service

### Warranty

All FETCO brewers come with a limited warranty. All warranty service must be pre-authorized by calling the FETCO Service Department at (800) 338-2699.

### Principles of Operation

#### Fill System

The fill system consists of a liquid level control board, a water level probe at the top of the tank, a fill valve, and a fill tube. As the water rises and touches the probe, continuity is established between the probe tip and the tank body, and the fill valve closes.

When water is dispensed, the water level drops below the probe. After a 5 second delay, the fill valve opens until the water touches the probe again.

The 5 second delay, and the speed that water refills the tank during brewing, results in many short bursts of water. The sound made by these repetitive bursts will let you know the fill system is functioning normally.

The fill system is designed to protect the heaters during both the installation and a loss of the water supply. During initial installation, or whenever the power switch is turned on, voltage will not be supplied to the thermostat until the tank fills and water touches the water level probe.

During operation, when water is dispensed and the water level drops below the probe, a fill signal is sent to the fill valve. If the probe senses no water after 40 seconds, the voltage to the thermostat and the heaters is removed.

Water enters the tank through the fill tube. A hole is drilled in the upper portion of the fill tube to prevent water from being siphoned from the tank. The fill tube extends to the bottom area of the tank. This introduces cold incoming water directly to the heaters and away from the dispense assembly.

The water tank can be drained through a valve located inside the lower compartment of the brewer.

#### Temperature System:

The temperature system consists of an electronic thermostat, a temperature probe, solid state relays (SSR), and heating elements, and is enabled by the liquid level control board. (See the previous section - Fill Circuit.)

When the water level probe is in contact with water, power is delivered to the thermostat through the liquid level control board. If the temperature probe senses that the water is not hot enough, the thermostat energizes the heating elements through the solid state relay (SSR), the water is heated, and the ready light goes off.

Once the water temperature reaches the set point, the thermostat disengages power to the heaters and the ready light illuminates.

The thermostat is adjusted to 205° F ± 2° at the factory. (Slightly lower for high altitude installations.)

## **Timing System:**

The timing system consist of the timer and the dispense latch assembly.

When the brew handle is rotated from the stop to the brew position, it pushes the plunger in the latch coil and closes the micro switch, and the timer starts the timed cycle. It also starts the hot water flowing.

The timer energizes the dispense latch coil, which acts as a magnet, to hold the brew handle in the brew position. It also lights the brew light. The coil remains energized throughout the brew cycle timed sequence.

When the timer finishes its cycle, it removes voltage from the latch coil. The latch coil then releases the brew handle, a spring returns it to the stop position, and the flow of water stops. This return opens the micro switch, stopping voltage from going to the timer. The brew light and the timer are disabled, and wait for the brew handle to engage the next brew cycle.

## **Dispense System:**

The dispense system is completely mechanical. It is one of the areas that makes FETCO's brewer truly unique. (See the illustration in this section.)

When you rotate the brew lever down to brew, the end of the dispense tube is submerged in the hot water tank. It is held in the brew position by the magnetic action of the dispense latch coil.

The brew water travels down the dispense tube to the sprayhead assembly. The flow disc above the spray cutter controls the rate of flow over the coffee. The standard hole in the flow disc is .240", except for the CBS-51H10, which is .219". Other flow discs are available for special situations like high levels of by-pass.

The sprayhead can be assembled incorrectly during cleaning. Refer to the cleaning label on the brewer for proper assembly. The flow disc has the flange down, flat side up. The six triangle spray cutter has the flange up. The eight hole spray cutter used in place of the triangle cutter goes bumps down.

A bypass valve and tube are connected to the sprayhead. This valve directs brew water around the outside edge of the filter paper. The by-pass valve is shipped in the closed position from the factory. Each time the valve is adjusted, the brew volume is affected. Adjustment of the by-pass valve is for flavor only.

When the timer circuit releases the brew latch, the dispense tube pops back above the hot water level. The remaining brew water drains from the dispense system leaving it free of standing water. Steam escaping from the brew tank through this tube inhibits the formation of lime in the brew system.

The dispense system is clean & semi dry for all but the brief time required for the brew cycle. This eliminates any chance of lime build-up affecting the brew cycle.

It is very easy to dislodge the dispense tube seals while servicing the dispense system. If you see it leaking profusely, remove the nut and dispense tube. Reset the seal fully into the recess and carefully insert the dispense tube. Then secure the locknut before you back the tube into position. (See detailed instructions on page 10.)

# Mechanical Illustration - Dispense System

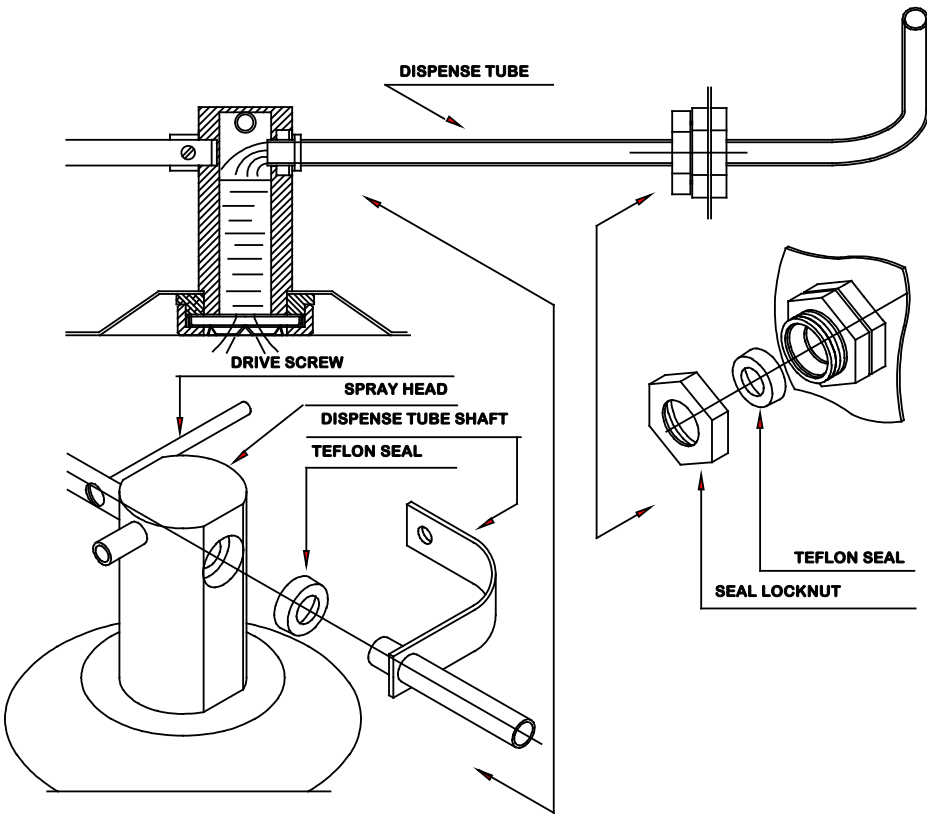
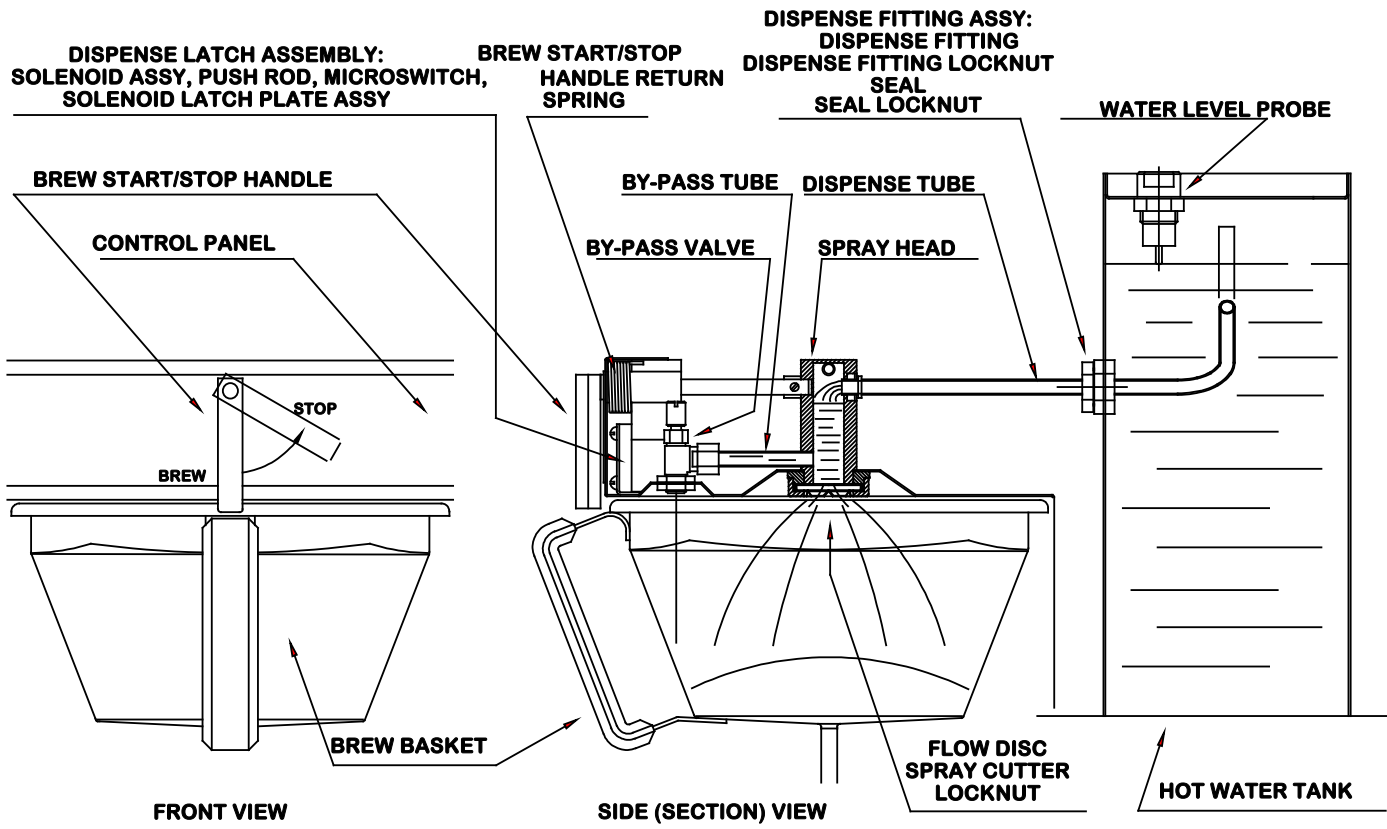

**To remove the dispense tube:**

1. Unscrew seal locknut and release the drive screw from dispense tube shaft.
2. Turn the dispense tube slightly back and forth, while pushing the tube into the hot water tank until it is free from the sprayhead.

Pull the dispense tube out of the tank. Remember the tube is bent inside the tank. The seal will come out with the tube.

**To install the dispense tube:**

1. Clean any lime build up off the tube and then slide the seal off. Push the seal carefully into its chamber in the fitting.(spring towards the hot water tank.)
2. Place the seal locknut onto the tube and slide the tube into the seal. Tighten the seal locknut.
3. Work the tube back into the sprayhead seal.
4. Join the dispense tube shaft and the brew handle shaft with the drive screw.

## Adjustments

### Thermostat Adjustment:

During normal operation, the digital readout displays the last two digits of the actual water temperature. When the adjustment tool is turned, the readout begins flashing to indicate the set point, not the actual temperature. After the tool is released, the readout stops flashing and displays the actual temperature again.

A red LED lights when the power to the thermostat is on. A yellow LED lights when the thermostat is calling for heat.

To adjust, turn the adjustment tool. If no adjustment tool is present, a small flat-head screwdriver may be used. The display will flash, indicating that the display is showing the set point, not the actual temperature.

The dots below the numbers indicate the temp range.

- 0 dots – less than 100° F
- 1 dot – between 100° and 200° F
- 2 dots – over 200° F

Examples:

**7 5** = 75°F

**8 7.** = 187°F

**0. 3.** = 203°F

Chart to correct for altitude boiling point difference in tank water temperature.					
[ft]	[m]	Suggested Setting[°F]	Boiling point[°F]	Suggested Setting[°C]	Boiling point [°C]
0	0	<b>205</b>	212.0	<b>96</b>	100.0
500	152	<b>205</b>	211.0	<b>96</b>	99.5
1000	305	<b>200</b>	210.1	<b>93</b>	98.9
2000	610	<b>200</b>	208.1	<b>93</b>	97.8
2500	762	<b>200</b>	207.2	<b>93</b>	97.3
3000	914	<b>200</b>	206.2	<b>93</b>	96.8
3500	1067	<b>197</b>	205.3	<b>92</b>	96.3
4000	1219	<b>195</b>	204.3	<b>91</b>	95.7
4500	1372	<b>194</b>	203.4	<b>90</b>	95.2
5000	1524	<b>194</b>	202.4	<b>90</b>	94.7
5500	1676	<b>193</b>	201.5	<b>89</b>	94.2
6000	1829	<b>192</b>	200.6	<b>89</b>	93.6
6500	1981	<b>191</b>	199.6	<b>88</b>	93.1
7000	2134	<b>190</b>	198.7	<b>87</b>	92.6
7500	2286	<b>188</b>	197.8	<b>86</b>	92.1
8000	2438	<b>187</b>	196.9	<b>86</b>	91.6
8500	2591	<b>185</b>	196.0	<b>85</b>	91.1

## Timer Adjustment:

The timer has two independent settings, with three dials for each setting. The first dial in each group sets 100 second increments, the second dial sets 10 second increments, and the third dial sets 1 second increments.

A red LED lights when the power to the timer is on. A yellow LED lights when the timer is running.

A small flat head screwdriver is required to adjust the dials.

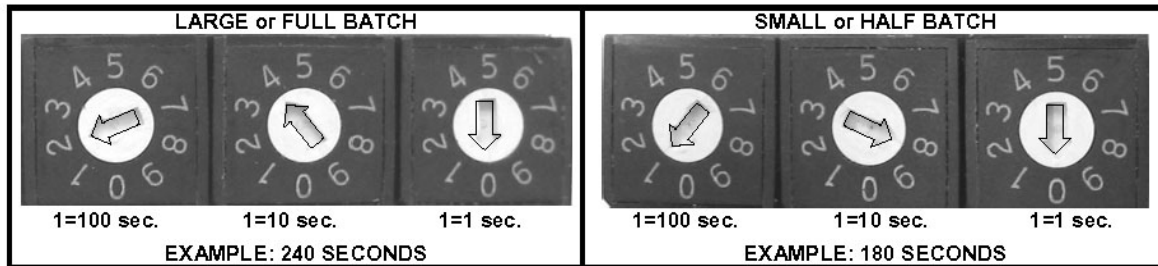

part # K034, digital timer, 100-120 VAC

part # K036, digital timer, 200-240 VAC (export versions only)

## Water Level Control Board:

The board features a jumper to adjust its' sensitivity for reverse osmosis or other types of ultra-pure water.

The default jumper setting is LO (50K ohms) for normal water. If the brewer tank overfills because of ultra-pure water, the jumper should be set to HI (100K ohms).

A red LED lights when the power to the board is on.

A green LED lights when the water level probe detects that the tank is full.

A yellow LED lights when the FILL circuit is energized.

A second yellow LED lights when the HEAT circuit is energized.

## Bypass Adjustment:

The purpose of the bypass valve is to allow a portion of the brewing water to flow between the brew basket and the wire insert, directly into the server, without coming in contact with the coffee grounds. The bypass can be adjusted from 0% to 33% of the total brewing water. Dual brewers (CBS-52H), have separate bypass valves on each side. Unless requested at the time of order, all brewers are shipped with the bypass valves closed (0%). Adjusting the bypass always changes the total brew volume, so the timer setting must always be checked and adjusted.

To adjust the bypass:

- Remove the brewer's upper cover.
- The bypass valve is located above the brew basket, to the right and to the front, as you are facing it.
- Remove the brew basket.
- Place a container under the spray head, and a separate container under the bypass hole.
- Turn the bypass valve clockwise to decrease, and counter-clockwise to increase the bypass amount. A good starting point would be one full turn for each 5% change.
- Brew a full cycle and measure the amount of water in both containers.
- The ratio of the bypass water to the total in both containers is the bypass percentage. example:  $\frac{1}{2}$  gal. bypass + 1 gal. from spray head = 1  $\frac{1}{2}$  gal. total. Bypass = 33.3%.
- Several adjustments may be necessary until the desired results are achieved.

Brewer Parts Figure 1 – CBS-51H15 Tank Assembly

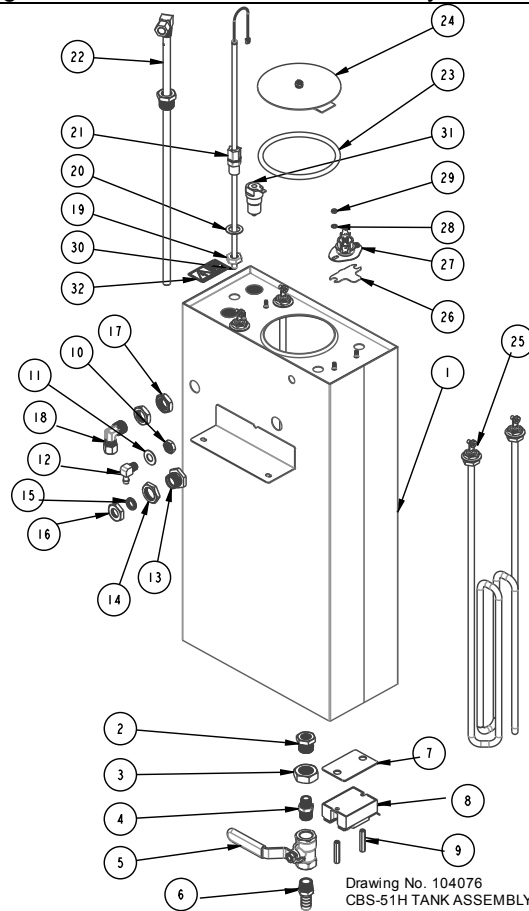

Drawing No. 104076  
CBS-51H TANK ASSEMBLY

REF	QTY	PART NO	DESCRIPTION
1	1	004072	WELDMENT, TANK, CBS-51H15 SRR
2	2	1031.00029.00	BUSHING, 3/4-16 X 1/4 NPSM, HEX HEAD
3	1	1084.00022.00	NUT, 3/4-16 HEX JAM, 18-8SS
4	1	1031.00026.00	FITTING, HEX NIPPLE, 3/8 NPT X 1/4 NPT
5	1	1034.00002.00	VALVE, BALL 3/8 FPT X 3/8 FPT
6	1	1031.00025.00	FITTING, BARB, 1/2 HOSE ID X 3/8 NPT
7	1	1003.00140.00	ALUMINUM BRACKET FOR SSR
8	1	1052.00033.00	RELAY, SOLID STATE, 50A/480VAC, W/BUILD IN VARISTOR
9	2	1081.00042.00	STANDOFF, 1/4" HEX
10	1	1031.00020.00	LOCKNUT 1/8" STRAIGHT PIPE THREAD
11	1	1083.00014.00	WASHER, .812"OD X 0.412"ID FLAT
12	1	1031.00032.00	FITTING, BARB, ELBOW 90°, 1/4 HOSE ID X 1/8 NPT
13	1	1013.00029.00	FITTING, DISPENSE, 7/16" DIA.
14	1	1013.00030.00	LOCKNUT, 7/16, DISPENSE FITTING
15	1	1024.00024.00	SEAL, DISPENSE TUBE, 7/16"DIA
16	1	1012.00003.00	LOCKNUT, SEAL, 7/16" DIA KEEPER
17	2	1031.00033.00	LOCKNUT, 3/8"-18 NPT THREAD
18	1	1031.00022.00	FITTING, ELBOW, 3/8" TUBE OD X 3/8" NPT
19	1	1023.00003.00	LOCKNUT, MODIFIED THREAD, 1/4-18 NPT
20	1	1083.00006.00	WASHER, .875" OD X 0.562" ID FLAT
21	1	1025.00001.00	FITTING, COMPRESSION MALE CONNECTOR
22	1	1112.00333.00	WELDMENT, TANK FILL TUBE
23	1	1024.00007.00	O-RING, DASH #344, TANK COVER
24	1	1102.00007.00	TANK COVER ASSEMBLY
25	1	107005	HEATER ASSEMBLY, IMMERSION 1800W, 120VAC
25	1 or 2	1107.00005.00	HEATER ASSEMBLY, IMMERSION 3000W, 240VAC
25	1 or 2	1107.00010.00	HEATER ASSEMBLY, IMMERSION 4000W/240VAC
26	1	1003.00005.00	BRACKET, ONE SHOT THERMOSTAT
27	1	1053.00004.00	THERMOSTAT, SINGLE SHOT, 25A
28	2	1083.00009.00	WASHER, #6 SCREW, INTL TOOTH LOCKWASHER
29	2	1084.00010.00	NUT, HEX, #6-32, UNDERSIZED, ZINC PLATED
30	1	30 1 102198	ASSEMBLY, DIGITAL TEMP. PROBE, 14.0"LG W/3/4" CABLE
31	1	102381	ASSEMBLY, LEVEL PROBE, 1.75" LG. X 0.25" DIA
32	1	1044.00004.00	LABEL, DANGER, HIGH VOLTAGE

For tank assembly and wiring diagram part numbers, call Tech Support at 800-338-2699. Provide the brewer serial number when calling

Figure 2 – CBS-51H15 Main Assembly

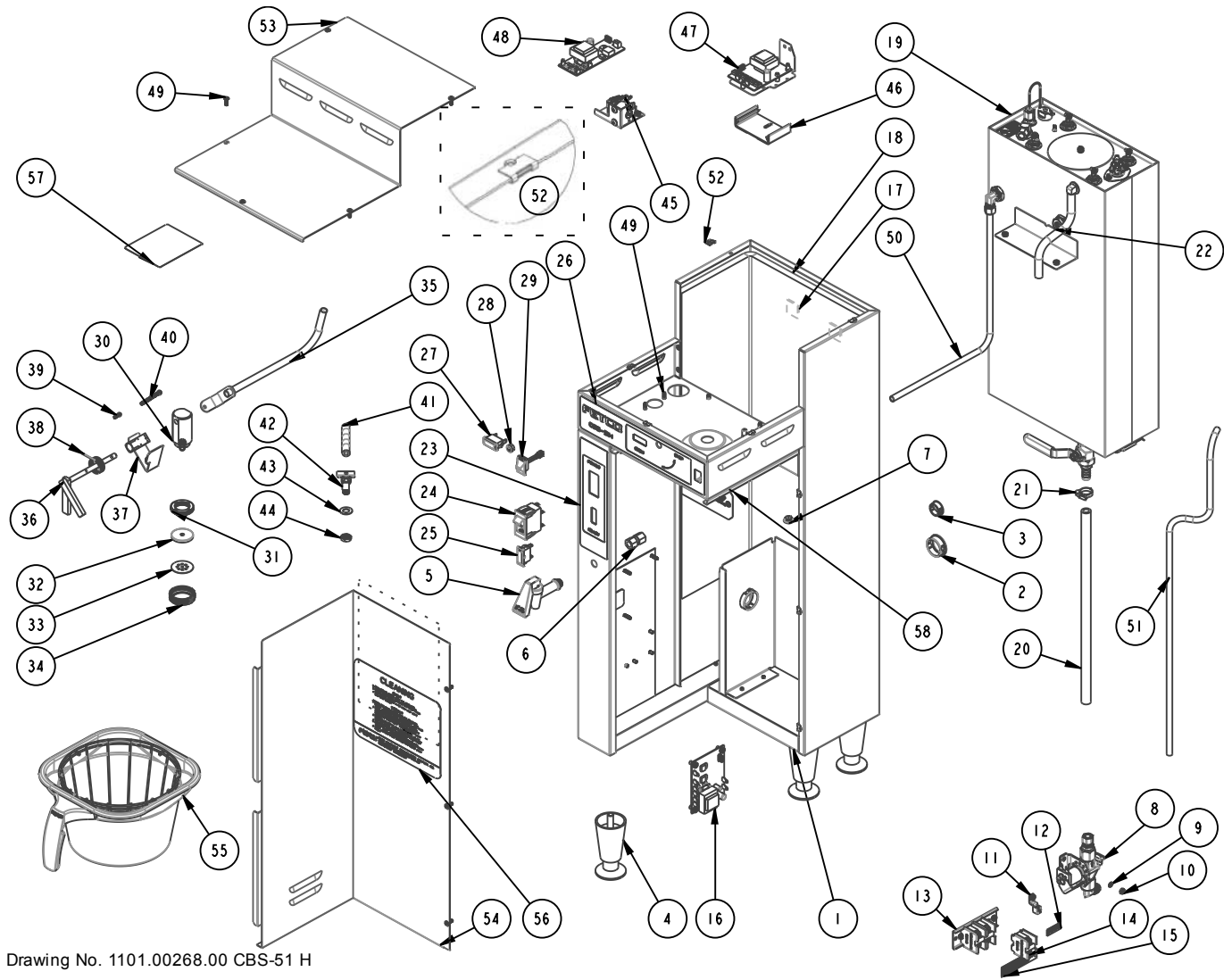

Drawing No. 1101.00268.00 CBS-51 H

REF	QTY	PART NO	DESCRIPTION	DRAWING NO. 1101.00268.00	NOTES
1	1	001009	WELDMENT, CBS-51H		
2	5	1086.00011.00	BUSHING, SNAP, 1.375 MTG HOLE		
3	1	86002	PLUG, DOME, .875 MOUNTING HOLE		
4	4	1073.00007.00	LEG, FLANGE FOOT, 4" HIGH		
5	1	1071.00010.00	FAUCET HPSC-BR-8 REGULAR HANDLE		
6	1	31023	FITTING, COMPR., CONNECTOR, 3/8 TUBE OD X 1/4 FPT		
7	1	86013	SNAP IN PLUG, 7/16" ID, SS		
		71039	FAUCET, UPPER ASSY.		
		71003	FAUCET SEAT CUP		
8	1	1102.00107.00	VALVE ASSEMBLY, S-45/1.4 GPM, 120VAC		
8	1	1057.00026.00	VALVE ASSEMBLY, S-45/1.4 GPM, 240VAC		EXPORT ONLY
9	12	1083.00011.00	WASHER, #8 SCREW SIZE, INTERNAL TOOTH LOCK		
10	12	1084.00006.00	NUT, 8-32 18-8 HEX MACHINE SCREW		
11	1	1065.00002.00	CONNECTOR, COPPER LUG		
12	1	1044.00003.00	LABEL GROUND		
13	1	1052.00005.00	TERMINAL BLOCK TRACK		
14	3	1052.00004.00	TERMINAL BLOCK		
15	1	1044.00015.00	LABEL, CONNECTION WARNING		
16	1	1108.00003.00	BOARD, ASSEMBLY, WATER LEVEL CONTROL, SELECTABLE		
16	1	108035	BOARD, ASSEMBLY, WATER LEVEL CONTROL, SELECTABLE 200-240VAC		EXPORT ONLY
17	2	1029.00035.00	HOOK - VELCRO, 1" LG		
18	1	1022.00093.00	INSULATION TANK BACK, 24" X 24", CBS-51H		
19	1	104116	TANK ASSEMBLY, CBS-51H15 SSR, 1X1.8kW/120VAC		
19	1	104026	TANK ASSEMBLY, CBS-51H15 SSR, 1X3kW/240VAC		
19	1	104076	TANK ASSEMBLY, CBS-51H15 SSR, 2X3kW/240VAC		
19	1	104118	TANK ASSEMBLY, CBS-51H15, SSR, 4KW, 240VAC		
19	1	104162	TANK ASSEMBLY, CBS-51H15, SSR, 2 x 4KW, 240VAC		
20	1	1025.00010.00	TUBE, 5/8"OD X 3/8"ID, DRAIN/FILL		
21	1	1086.00002.00	CLAMP, HOSE, SIZE "G" NYLON		
22	1	25021	SILICONE TUBE, 1/2" OD x 1/4" OD x 6-1/2" LG.		
23	1	1045.00021.00	OVERLAY, VERTICAL PANEL, CBS-51/52H		
24	1	1052.00003.00	BREAKER, CIRCUIT, 240VAC, ROCKER SWITCH, 6AMP		
25	1	1058.00009.00	LAMP, READY INDICATOR, GREEN, 110VAC		
25	1	1058.00018.00	LAMP, READY INDICATOR, GREEN 220VAC		EXPORT ONLY
26	1	1045.00022.00	OVERLAY, CONTROL PANEL, CBS-51H		
27	1	1058.00011.00	LAMP, BREW INDICATOR, CLEAR, 110VAC		
27	1	58004	LAMP, BREW INDICATOR, CLEAR 220VAC		EXPORT ONLY
28	1	1086.00036.00	BUSHING, .312 X .500" HEAD DIA. SHORTY		
29	1	1102.00053.00	ASSY., SWITCH SLIDE, FULL/HALF W/ TERMINALS		
30	1	102320	ASSEMBLY SPRAY HEAD, CBS-50's		
31	1	1013.00094.00	LOCKNUT, SPRAY HEAD		
32	1	1005.00016.00	FLOW DISC, .240 DIA		
33	1	1005.00003.00	SPRAY CUTTER, 8+1, .075" CENTER		
34	1	1012.00004.00	LOCKNUT, SPRAY CUTTER		
35	1	1112.00041.00	DISPENSE TUBE, WELDMENT, CBS-50'S		
36	1	102010	BREW HANDLE START/STOP ASSY.		
37	1	102022	ASSEMBLY, DISPENSE LATCH, CBS-50'S		
38	1	85004	SPRING, BREW HANDLE RETURN		
39	1	1082.00093.00	SCREW, ROUND HD. PHIL. MACH., #6-32 X 5/8" LG., 18-8 SS		
40	1	1082.00092.00	SCREW, PAN HD. PHIL. MACH., #8-32 X 2-1/4" LG., 18-8 SS		
41	1	25001	TUBE SILICONE, 1/2" x 1/4" ID x 2-7/8" LG.		
42	1	1102.00296.00	ASSEMBLY, BYPASS, CBS-50/60		
43	1	1083.00014.00	WASHER, .812"OD X 0.412"ID FLAT		
44	1	1031.00020.00	LOCKNUT 1/8" STRAIGHT PIPE THREAD		
45	1	1102.00295.00	ASSEMBLY DISPENSE SOLENOID LATCH, CBS-50/60		
45	1	102039	ASSEMBLY DISPENSE SOLENOID LATCH, CBS-50/60, 240VAC		EXPORT ONLY
46	1	1102.00298.00	ASSEMBLY PLASTIC TRACK 2", TIMER		
47	1	102270	ASSEMBLY, DIGITAL TIMER 100-120VAC		
47	1	1000.00036.00	ASSEMBLY, DIGITAL TIMER 200-240VAC		EXPORT ONLY
48	1	108032	ASSEMBLY, BOARD THERMOSTAT DIGITAL/ANALOG 100-120VAC		
48	1	1000.00035.00	Kit THERMOSTAT DIGITAL/ANALOG 200-240VAC		EXPORT ONLY
49	10	41082.00017.00	SCREW, TRUSS HD. PHIL. MACHINE, # 6-32 X 1/2 LG.		
50	1	1032.00030.00	TUBE TANK TO FAUCET, CBS-51H15		
51	1	1032.00031.00	TUBE FILL VALVE, TANK, CBS-51H15		
52	8	1084.00011.00	NUT, CLIP ON (J-NUT), #6-32, 22-20 GA., BLK-PH FINISH		
53	1	01133	COVER, UPPER CBS-51H		
54	1	002023	WELDMENT, LOWER COVER CBS-50'S		
55	1	B001280B1	BB ASSY, 16" X 6", 0.280 DIA HOLE, BLACK		
56	1	46013	LABEL, CLEANING INSTRUCTIONS		
57	1	46035	LABEL, HOW TO ADJUST DIGIT. TIMER, THERMOSTAT & L.L.C.B.		
58	1	1046.00020.00	TAG, INFORMATION		

Figure 3 – CBS-52H15 & CBS-52H20 Main Assembly

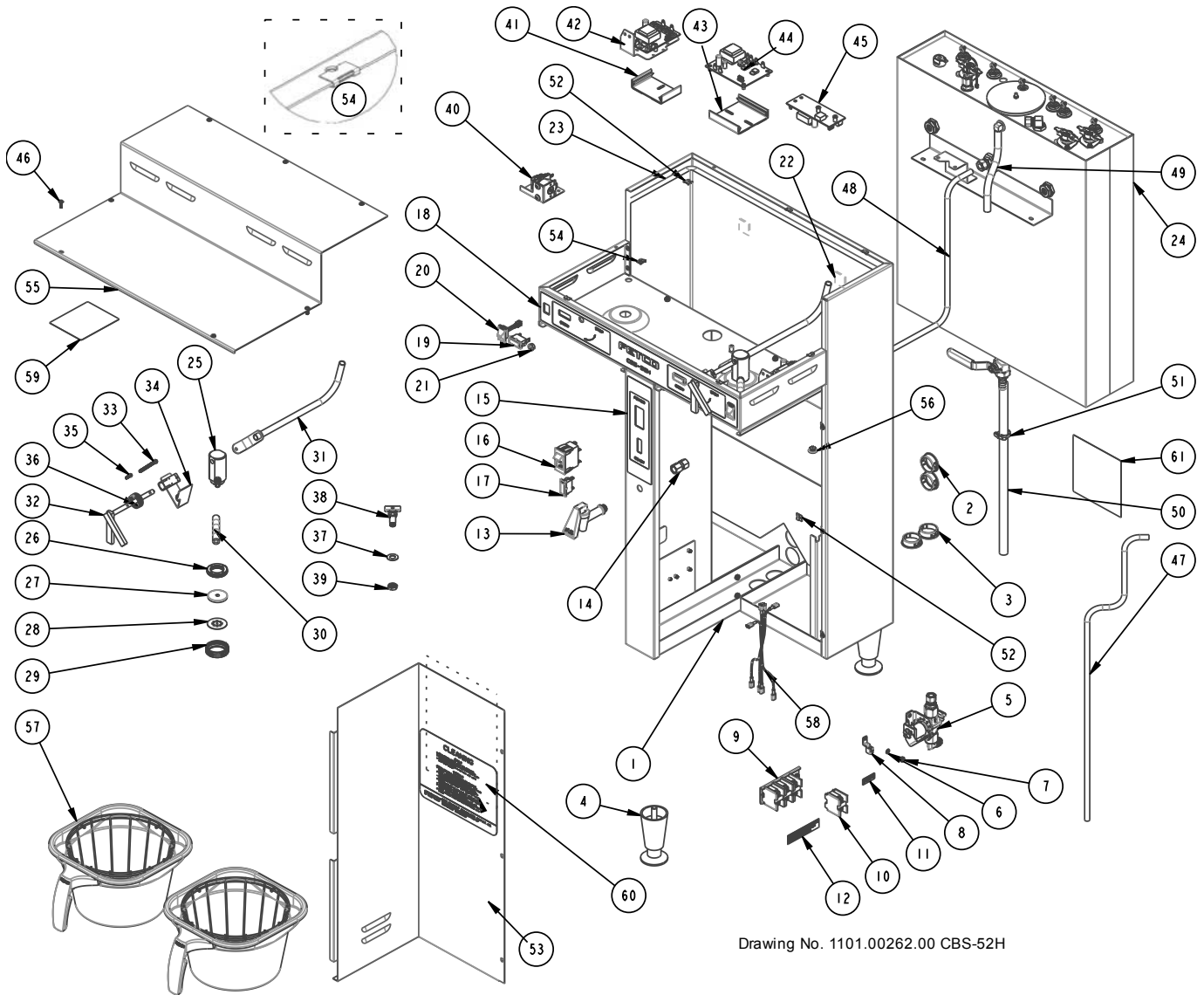

Drawing No. 1101.00262.00 CBS-52H

REF	QTY	PART NO	DESCRIPTION	Notes
1	1	001008	WELDMENT CBS-52H15	
2	4	1086.00011.00	BUSHING, SNAP, 1.375 MTG HOLE	
3	2	1086.00019.00	PLUG, DOME, 1.375 MOUNTING HOLE	
4	3	1073.00007.00	LEG, FLANGE FOOT, 4" HIGH	
5	1	1102.00107.00	VALVE ASSEMBLY, S-45/1.4 GPM, 120VAC	
5	1	1057.00026.00	VALVE ASSEMBLY, S-45/1.4 GPM, 240VAC	EXPORT ONLY
6	11	1083.00011.00	WASHER, #8 SCREW SIZE, INTERNAL TOOTH LOCK	
7	11	1084.00006.00	NUT, 8-32 18-8 HEX MACHINE SCREW	
8	1	1065.00002.00	CONNECTOR, COPPER LUG	
9	1	1052.00005.00	TERMINAL BLOCK TRACK	
10	4	1052.00004.00	TERMINAL BLOCK	
11	1	1044.00003.00	LABEL GROUND	
12	1	1044.00015.00	LABEL, CONNECTION WARNING	
13	1	1071.00010.00	FAUCET HPSC-BR-8 REGULAR HANDLE	
		71039	FAUCET, UPPER ASSY. (SUBCOMPONENT OF #7)	
		71003	FAUCET SEAT CUP (SUBCOMPONENT OF #7)	
14	1	31023	FITTING, COMPR., CONNECTOR, 3/8 TUBE OD X 1/4 FPT	
15	1	1045.00021.00	OVERLAY, VERTICAL PANEL, CBS-51/52H	
16	1	1052.00003.00	BREAKER, CIRCUIT, 240VAC, ROCKER SWITCH, 6AMP	
17	1	1058.00009.00	LAMP, READY INDICATOR, GREEN, 110VAC	
17	1	1058.00018.00	LAMP, READY INDICATOR, GREEN 220VAC	EXPORT ONLY
18	1	1045.00020.00	OVERLAY, CONTROL PANEL, CBS-52H	
19	2	1058.00011.00	LAMP, BREW INDICATOR, CLEAR, 110VAC	
19	2	58004	LAMP, BREW INDICATOR, CLEAR 220VAC	EXPORT ONLY
20	2	1102.00053.00	ASS'Y., SWITCH SLIDE, FULL/HALF W/ TERMINALS	
21	2	1086.00036.00	BUSHING, .312 X .500" HEAD DIA. SHORTY	
22	2	1029.00035.00	HOOK - VELCRO, 1" LG	
23	1	1022.00091.00	INSULATION TANK BACK, 24"X34", CBS-52H15	
24	1	104123	ASS'Y. TANK, CBS-52H, SSR, 2x3KW, 240VAC	
24	1	104075	ASS'Y. TANK, CBS-52H, SSR, 3X3KW/240VAC	
24	1	104124	ASS'Y. TANK, CBS-52H, SSR, 2 x 4KW, 240VAC	
24	1	104161	ASS'Y. TANK, CBS-52H, SSR, 3 x 4KW, 240VAC	
25	2	102320	ASSEMBLY SPRAY HEAD, CBS-50's	
26	2	1013.00094.00	LOCKNUT, SPRAY HEAD	
27	2	1005.00016.00	FLOW DISC, .240 DIA	
28	2	1005.00003.00	SPRAY CUTTER, 8+1, .075" CENTER	
29	2	1012.00004.00	LOCKNUT, SPRAY CUTTER	
30	2	25001	TUBESILICONE, 1/2" x 1/4" ID x 2-7/8" LG.	
31	2	1112.00041.00	DISPENSE TUBE, WELDMENT, CBS-50'S	
32	1	102010	BREW HANDLE START/STOP ASS'Y.	
33	2	1082.00092.00	SCREW, PAN HD. PHIL. MACH., #8-32 X 2-1/4" LG., 18-8 SS	
34	2	102022	ASSEMBLY, DISPENSE LATCH, CBS-50'S	
35	2	1082.00093.00	SCREW, ROUND HD. PHIL. MACH., #6-32 X 5/8" LG., 18-8 SS	
36	2	85004	SPRING, BREW HANDLE RETURN	
37	2	1083.00014.00	WASHER, .812"OD X 0.412"ID FLAT	
38	2	1102.00296.00	ASSEMBLY, BYPASS, CBS-50/60	
39	2	1031.00020.00	LOCKNUT 1/8" STRAIGHT PIPE THREAD	
40	2	1102.00295.00	ASSEMBLY DISPENSE SOLENOID LATCH, CBS-50/60	
40	2	102039	ASSEMBLY DISPENSE SOLENOID LATCH, CBS-50/60, 240VAC	EXPORT ONLY
41	2	1102.00298.00	ASSEMBLY PLASTIC TRACK 2", TIMER	
42	2	102270	ASSEMBLY, DIGITAL TIMER 100-120VAC	
42	2	1000.00036.00	ASSEMBLY, DIGITAL TIMER 200-240VAC	EXPORT ONLY
43	1	1102.00299.00	ASSEMBLY PLASTIC TRACK, 3"LG. LLC	
44	1	1108.00003.00	BOARD, ASSEMBLY, WATER LEVEL CONTROL, SELECTABLE	
44	1	108035	BOARD, ASSEMBLY, WATER LEVEL CONTROL, SELECTABLE 200-240VAC	EXPORT ONLY
45	1	108032	ASSEMBLY, BOARD THERMOSTAT DIGITAL/ANALOG 100-120VAC	
45	1	1000.00035.00	Kit THERMOSTAT DIGITAL/ANALOG 200-240VAC	EXPORT ONLY
46	13	1082.00017.00	SCREW, TRUSS HD. PHIL. MACHINE, # 6-32 X 1/2 LG.	
47	1	1032.00027.00	TUBE FILL VALVE, TANK, CBS-52H15	
48	1	1032.00026.00	TUBE, TANK TO FAUCET, CBS-50H	
49	1	25021	TUBE SILICONE, 1/2" OD x 1/4" OD x 6-1/2" LG.	
50	1	1025.00010.00	TUBE, 5/8"OD X 3/8"ID, DRAIN/FILL	
51	1	1086.00002.00	CLAMP, HOSE, SIZE "G" NYLON	
52	6	1084.00024.00.	NUT, CLIP ON (J-NUT), #6-32, 1050 SPR. STL	
53	1	002023	WELDMENT, LOWER COVER CBS-50'S	
54	4	1084.00011.00	NUT, CLIP ON (J-NUT), #6-32, 22-20 GA., BLK-PH FINISH	
55	1	01056	UPPER COVER, CBS-52H	
56	2	86013	SNAP IN PLUG, 7/16" ID, SS	
57	2	B001280B1	BB ASSY, 16" X 6", 0.280 DIA HOLE, BLACK	
58	1	402083	HARNESS LOW AMP, SSR VERSION, CBS-52H, UNIVERSAL	
59	1	46035	LABEL, HOW TO ADJUST DIGIT. TIMER, THERMOSTAT & L.L.C.B.	
60	1	46013	LABEL, CLEANING INSTRUCTIONS	
61	1	1046.00035.00	LABEL, WARNING "TO REDUCE RISK OF ELECTRIC SHOCK OR FIRE"	

**Figure 4 – CBS-52H15 & CBS-52H20 Tank Assembly**

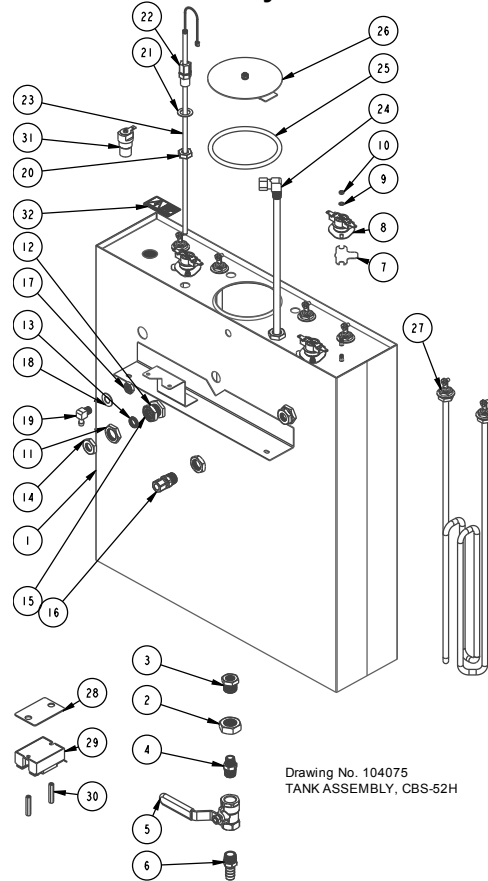

REF	QTY	PART NO	DESCRIPTION
1	1	1114.00133.00	WELDMENT TANK, CBS-52H
2	1	1084.00022.00	NUT, 3/4-16 HEX JAM, 18-8SS
3	2	1031.00029.00	BUSHING, 3/4-16 X 1/4 NPSM, HEX HEAD
4	1	1031.00026.00	FITTING, HEX NIPPLE, 3/8 NPT X 1/4 NPT
5	1	1034.00002.00	VALVE, BALL 3/8 FPT X 3/8 FPT
6	1	1031.00025.00	FITTING, BARB, 1/2 HOSE ID X 3/8 NPT
7	1-3	1003.00005.00	BRACKET, ONE SHOT THERMOSTAT
8	1-3	1053.00004.00	THERMOSTAT, SINGLE SHOT, 25A
9	6	1083.00009.00	WASHER, #6 SCREW, INTL TOOTH LOCKWASHER
10	6	1084.00010.00	NUT, HEX, #6-32, UNDERSIZED, ZINC PLATED
11	2	1013.00030.00	LOCKNUT, 7/16, DISPENSE FITTING
12	2	1013.00029.00	FITTING, DISPENSE, 7/16" DIA.
13	2	1024.00024.00	SEAL, DISPENSE TUBE, 7/16"DIA
14	2	1012.00003.00	LOCKNUT, SEAL, 7/16" DIA KEEPER
15	2	1031.00033.00	LOCKNUT, 3/8"-18 NPT THREAD
16	1	1031.00024.00	FITTING, COMP., MALE CONN., 3/8 TUBE X 3/8
17	1	1031.00020.00	LOCKNUT 1/8" STRAIGHT PIPE THREAD
18	1	1083.00014.00	WASHER, .812"OD X 0.412"ID FLAT
19	1	1031.00032.00	FITTING, BARB, ELBOW 90°, 1/4 HOSE ID X 1/8 NPT
20	1	1023.00003.00	LOCKNUT, MODIFIED THREAD, 1/4-18 NPT
21	1	1083.00006.00	WASHER, .875" OD X 0.562" ID FLAT
22	1	1025.00001.00	FITTING, COMPRESSION MALE CONNECTOR
23	1	1102.00291.00	ASSEMBLY DIGITAL TEMP. PROBE, 14.0"LG.
24	1	1112.00333.00	WELDMENT, TANK FILL TUBE
25	1	1024.00007.00	O-RING, DASH #344, TANK COVER
26	1	1102.00007.00	TANK COVER ASSEMBLY
27	1-3	1107.00005.00	HEATER ASSEMBLY, IMMERSION 3000W, 240VAC
27	1-3	1107.00010.00	HEATER ASSEMBLY, IMMERSION 4000W/240VAC
28	1-3	1003.00140.00	ALUMINUM BRACKET FOR SSR
29	1-3	1052.00033.00	RELAY, SOLID STATE, 50A/480VAC, W/BUILD IN VARISTOR
30	6	1081.00042.00	STANDOFF, 1/4" HEX
31	1	1102.00292.00	ASSEMBLY, LEVEL PROBE, 1.75" LG. X 0.25" DIA
32	1	1044.00004.00	LABEL, DANGER, HIGH VOLTAGE

For tank assembly and wiring diagram part numbers, call Tech Support at 800-338-2699. Provide the brewer serial number when callin

**Figure 5 – Brew Basket Assembly, 16" X 6", Part # B001280B1**

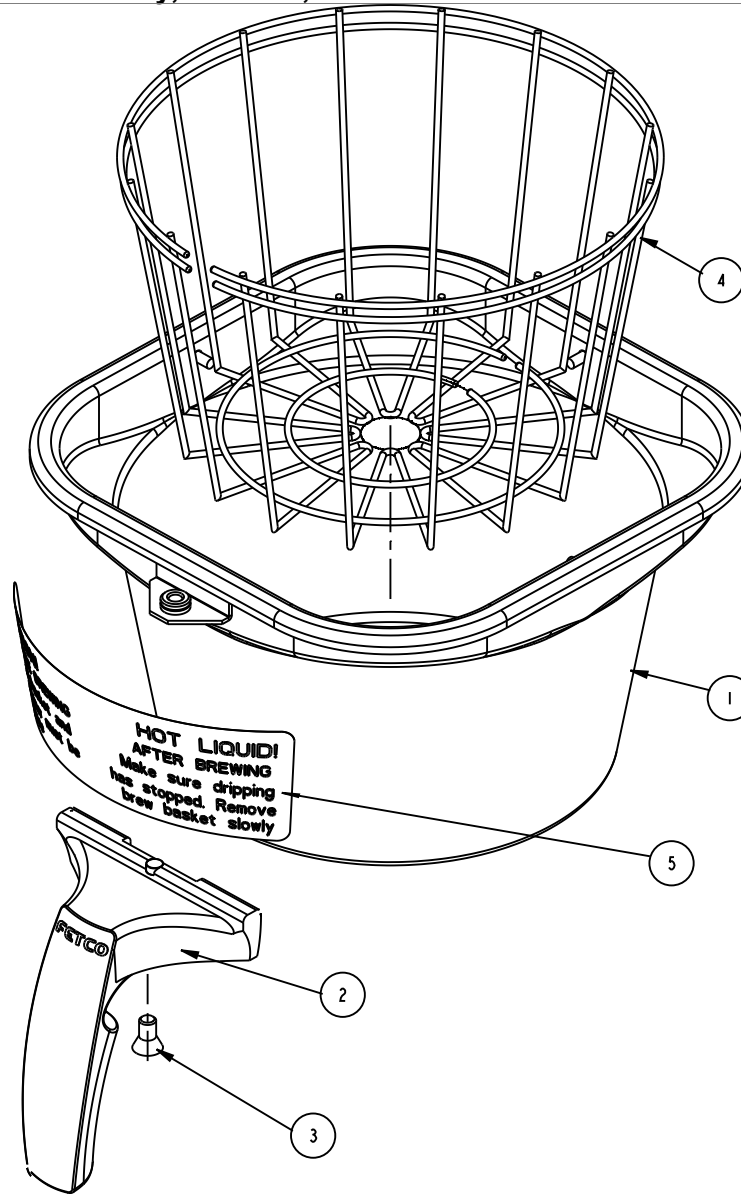

ITEM	QTY	PART #	DESCRIPTION
1	1	1112.00058.00	BB WDMT, 16"X6", SQUARE, 0.280 in~ HOLE
2	1	1102.00064.00	BREW BASKET HANDLE, BLACK (includes magnet)
3	1	1082.00040.00	HANDLE SCREW
4	1	1009.00005.00	WIRE INSERT, 16 X 6
5	1	1046.00025.00	WARNING LABEL
NOT SHOWN		F001	PAPER FILTERS, 15" X 5.5" 500 PER CASE
NOT SHOWN		F002	PAPER FILTERS, 13" X 5" Optional -Half Batch 500 PER CASE

**COLOR BREW BASKET HANDLES (optional)**

PART #	DESCRIPTION
1023.00087.00	BREW BASKET HANDLE, GREEN
1023.00088.00	BREW BASKET HANDLE, ORANGE
1023.00090.00	BREW BASKET HANDLE, RED

## Troubleshooting

Brewing Problem	Possible Cause	Solution
<b>Brew handle</b> will not stay down	Power switch off.	-Turn switch on.
	No power to the brewer (Brewer lights are not illuminated)	-Make sure the brewer is plugged in. -Check the wall circuit breaker / reset -Turn the brewer power switch off then back on (it has an internal breaker)
	Bad timer or dispense latch assembly. (Brew light <b>does not</b> come on and handle won't stay down)	-Check for voltage reaching the timer from the dispense latch assembly if yes replace timer. If no, replace latch assy.
	Bad dispense latch assy. (Brew light <b>does</b> come on and handle won't stay down)	-Replace the dispense latch assembly
	Bad dispense latch assembly (brewer buzzes when in brew cycle)	-Replace the dispense latch assembly
<b>Brew handle</b> stays down but no water is dispensed	No water reaching the brewer	-Make sure the shut off valve is open. -Check water line for kinks; replace line if necessary -Check to see if filter is clogged by changing it.
<b>Short brew levels EVERY BREW</b>  (One or Both sides are affected and levels are <b>consistent</b> )	Flow discs in spray heads in upside down	-Reassemble spray heads - bumps on spray cutter face ↓ with flange on flow disc facing ↓
	Water filter clogged	(See details in next section)
	Spray head clogged	-Clean and or replace the sprayhead
	Timer/s are set too low	-Advance timers to proper level.
	Incoming Voltage is too low for timers to function at proper time sequences	-Reset wall circuit breaker as one side may drop out & not flag the breaker. -Call an electrician to find loose connections in the building
<b>Short brew levels SOME BREWS</b>  (One or Both sides are affected and levels are <b>erratic</b> )	Water filter clogged. (problem is worse during simultaneous brews)	-Replace water filter
	Weak dispense latch assembly (usually buzzes during cycle)	-Replace dispense latch assembly.
	Water pressure or flow rate is too low or fluctuates too much to support a full brew. (problem is worse in simultaneous brews)	-Make sure brewer has a dedicated water line -Ensure that the shut off valve is open all the way (Never use needle saddle valves) -Increase the diameter of the water line to the brewer and or find stable source.
<b>Brew Time required to fill LUXUS are not the same for both sides</b>	Brewer is not level	-With an accurate level, level the brewer front to back and left to right by adjusting the feet.
<b>High brew levels EVERY BREW</b> (overfills but does stop) <b>SOME BREWS</b>	Timer/s are set too high	-Adjust timers down to appropriate level
	Thermal server not empty	-Empty the server and try again
<b>Brew basket or filter overflows</b>		-Call FETCO Service Dept. to discuss. (800) 338-2699
<b>Weak Coffee</b>	Spray head missing	-Attach spray head assembly.
	Improper dose	-Measure and confirm correct dose
	Filter papers	-Make sure only one paper is used
	Cracked dispense tube	-See "spray head drips MAJOR", below
	Low brew temperature (Temperature inside the hot water tank is set to 205° F, the metal delivery system drops the temp.)	-Adjust thermostat so the water stream measured at the bottom of the brew basket, 1/3 of the way through the brew cycle, equals 190 degrees + or - 5 degrees
<b>Grounds not saturated</b>	Spray head missing	-Replace spray head
	Half batch used incorrectly	-Use smaller "half batch" brew basket -Discourage half batch use -Investigate the need for a smaller brewer
	Water Softener in use	-Move brewer water feed to a non-softened source.
	Degassing - extremely fresh coffee	-Call FETCO Service Dept. to discuss. (800) 338-2699
<b>No bypass EVERY BREW →</b> <b>SOME BREWS →</b>	Bypass valve closed	-Open bypass valve
	Flow disc wrong size or missing	-Correct or replace flow disc
<b>Spray head / brew basket drips either side or both</b> MINOR	Condensation around the sprayhead area	-Wipe sprayhead area after brewing; place an empty container under brew cone when not in use.
	Condensation from water tank dripping through dispense tube	-Insert an empty brew basket and server under brew heads when not in use

Brewing Problem	Possible Cause	Solution
<b>Spray head / brew basket drips either side or both</b> MAJOR	Cracked dispense tube/s (This problem starts out minor but gets steadily worse)	-Replace both dispense tubes even if other side is not dripping
	Fill valve not sealing (Will drip even with power off.)	-See next section - "Brewer won't stop brewing", "Bad or stuck fill valve".
<b>Brewer won't stop brewing</b> (not same as high brew levels)	Dispense tube cracked	-See "sprayhead drips MAJOR" above
	Mechanical binding (brew handle stays down / brew light turns off at normal time)	-Re-align the brew handle / brass sprayhead tower / and dispense tube into a straight line by moving brass tower
	Water pressure over 75psi	-Place a water pressure regulator on the line and reduce to 20-75 psi
	Dispense tube drive screw off. A 2.5" screw that connects the handle to the dispense tube at the brass sprayhead tower. (handle returns up and brew lamp turns off but brewing continues)	-Ensure that the drive screw is straight (can be straightened by hand while still in the brew handle) and reconnect to the dispense tube. The flange that the drive screw engages MUST be held flat against the brass sprayhead tower, without being able to back out.
	Water level probe bad or encrusted with lime. (causes brewer to continue filling hot water tank which will overflow into the brew baskets)	-Clean lime build up on the probe tip and/or tank wall. (Holding the probe wire (green) from the probe end to the body of the brewer should stop the fill if the probe is bad but the liquid level board is good)
	Bad liquid level control board	-Replace the LLC board if grounding the probe end of the (green) probe wire to the body of brewer does not remove the voltage at the fill terminal on the LLC board.
	Bad or stuck fill valve	-Rebuild or replace the fill valve if no voltage is on the coil (it is not magnetic) and it still passes water to the tank. (Disconnect the outlet side to see if it leaks water to the tank)
<b>Coffee tastes too strong</b>	Incorrect dosage	-Measure and confirm the correct amount of coffee required
	Short brew levels	-See "Short brew levels", above.

Temperature Problem (brewer only)	Possible Cause	Solution
<b>See also LUXUS problems</b>		
<b>Brew water is cold / not hot enough, ready light is OFF.</b> (Before proceeding, make sure water tank refills when water is dispensed. The brewer will not heat unless the tank is full.)	No power to brewer.	-Make sure power switch is on. -Reset machine circuit breaker. -Check power connection. (plug or hard wire connection). -Check building circuit breaker. (Always reset breaker by switching off, then on.)
	Defective liquid level control board. (No power to thermostat).	-With power on, and water tank full, check LLC board for 120 volts on brown wire and neutral. Replace LLC board if there is no voltage.
	Bad connections on solid state relay. (No power to heaters).	-Check relay for burned or loose connections. Replace with high temperature connectors if necessary.
	Defective solid state relay. (No power to heaters).	-Check input and output voltages on relay. 120 volts on blue wire (input) but no voltage out to heaters indicates a bad relay.
	Bad heating element/s.	-Check amperage draw on heater wires. 0 amps = bad heater.
<b>Brew water is cold / not hot enough, ready light is ON.</b>	Bad Thermostat (the thermostat believes that it is at set temperature)	-Replace the thermostat and or thermal probe. It's not possible to trouble shoot the probe.
	Low brew temperature setting on thermostat	-See "Low brew temperature" under " <b>Weak Coffee</b> " section.
<b>Slow to recover temperature</b> (Ready light takes along time to come back on after brewing.)	Brewers with more than one heater can have just one fail	-Check amperage draw on heater wires. 0 amps = bad heater.
	Hot water tank limed up	-Remove access cover to the hot water tank and inspect for lime. Remove the brewer for shop de-liming if build up is thick.
<b>Boiling</b>	Thermostat set too high for altitude (Denver etc.)	-Reduce temperature setting to 3 degrees below boiling at your altitude
	Defective thermostat	-Replace the thermostat and or thermal probe. It's not possible to trouble shoot the probe.